

Wabo®SeismicPan

Floor Seismic Expansion Control System

Features	Benefits
<ul style="list-style-type: none"> • Durable 	Limited maintenance.
<ul style="list-style-type: none"> • Pedestrian friendly 	Complies with ADA requirements.
<ul style="list-style-type: none"> • Versatile 	Easily modified to enhance moisture protection and can be custom designed to meet specific project requirements
<ul style="list-style-type: none"> • Multi-directional movement 	Protects structure and building occupants during earthquake activity.

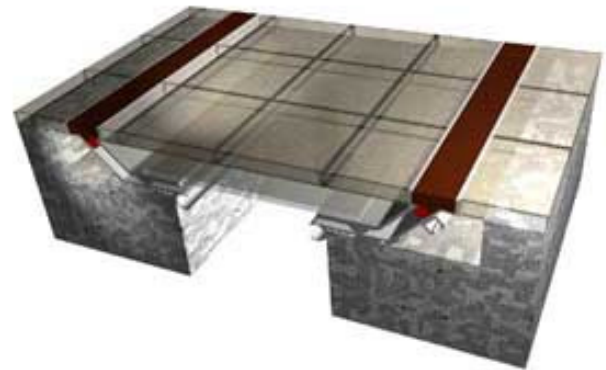

DESCRIPTION:

Wabo®SeismicPan expansion joints incorporate design features such as heavy-duty, but elegant edges frames with a center pan designed to accommodate 150 PSF distributed live load. The colorable, elastomeric sealant supplied by the installer completes the joint installation.

Wabo®SeismicPan is capable of accommodating multi-directional seismic movement including lateral shear, without stress to its components during thermal movement. This nearly invisible system meets ADA Guidelines and stays flush during thermal movement and rises upward during a seismic event, permitting full movement within the structural joint opening.

The heavy-duty aluminum pan and components are heavier in thickness and size than most systems offered in the market place, extending the performance and life span of the system.

RECOMMENDED FOR:

- Interior/Exterior floor expansion joint applications.
- For use in various construction projects including:
 - Health-Care
 - Transportation
 - Recreation
 - Retail
 - Commercial
 - Educational

PACKAGING/COVERAGE:

- Aluminum profiles shipped in 10 ft. lengths.
- All aluminum profiles are supplied in standard mill finish.
- All material and components palletized and/or packaged in manufacturer's standard labeled carton.

TECHNICAL DATA:

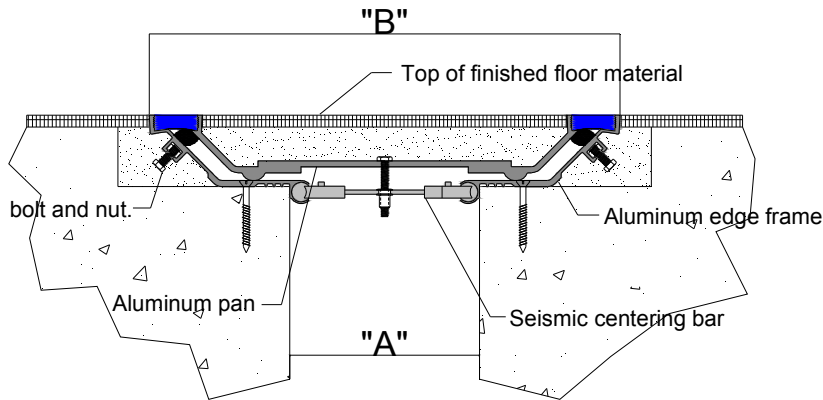

Note: see product sales drawings for additional details

Model SPJ

Movement Table

Model Number	Joint Opening ("A")		System Width (at mid) "B"		Total Movement	
	inches	mm	inches	mm	inches	mm
SPJ-200	2.0	51	10.81	275	3.00	76
SPJ-400	4.0	100	12.88	327	4.75	121
SPJ-600	6.0	152	14.88	378	7.75	197
SPJ-800	8.0	203	18.88	479	10.75	273
SPJ-1000	10.0	254	20.88	530	13.75	349
SPJ-1200	12.0	305	23.88	606	16.75	425
SPJ-1600	16.0	406	29.88	759	22.75	578
SPJ-1800	18.0	457	34.88	886	25.75	654
SPJ-200C	2.0	51	6.44	164	1.38	35
SPJ-400C	4.0	100	8.44	214	3.00	76
SPJ-600C	6.0	152	10.44	265	5.50	140
SPJ-800C	8.0	203	13.44	341	8.00	203
SPJ-1000C	10.0	254	15.44	392	10.50	267
SPJ-1200C	12.0	305	17.94	456	13.00	330
SPJ-1600C	16.0	406	22.94	583	18.00	457
SPJ-1800C	18.0	457	26.44	672	20.50	521

Note: Custom sizes and heavy load applications are available. Contact WBA for additional information.

PHYSICAL PROPERTIES:

Aluminum Extrusions and Shapes: Materials shall conform to properties of ASTM B221, 6063-T6 or ASTM B209, 6063-T6 aluminum alloy.

Self-Centering Bar: Manufactured incorporating corrosion resistant nylon components with spherical ends.

Moisture Barrier (optional): Fabric reinforced tear resistant clear vinyl sheet material. Minimum thickness shall be 0.026”.



APPLICATION:

Installation Summary:

- Protect all expansion joint components from damage during installation and protect finished installation from damage from other trades during all work activities.
- Expansion joint systems shall be installed in accordance with manufacturer's typical details and installation procedures.
- Floor construction and materials shall be designed to allow for proper installation of system and its components. Construct all blockouts in accordance with manufacturer's recommendations.
- Construct joint openings consistent in width and straight along joint length. Inspect and verify all substrates to be solid and sound prior to work. Remove any loose materials and repair any voids, and/or spalls with appropriate repair material.
- Construct all adjacent floors to be horizontally flat along length and flush across both sides of the opening. Inspect and verify all substrates to be solid and sound prior to work.
- Install appropriate fire barrier system, if required by building code and rated construction. Contact WBA for recommendations on appropriate fire barrier system.
- Metal components shall be cut to length on job site where required. Components shall be miter cut in the field to conform to directional changes unless otherwise contracted with expansion joint manufacturer.
- All anchor holes shall be field drilled in accordance with manufacture's drawings.

For Best Results:

- Do not install if the joint's anticipated movement will exceed the system's movement range.
- Deliver product in each manufacturer's original, intact, labeled containers. Protect the work area with appropriate plastic sheeting.
- Do not allow any of the components to freeze prior to installation. Store all components out of direct sunlight in a clean, dry location between 50°F (10°C) and 90°F (32°C). Store off the ground and protect from weather and construction activities.
- For applications requiring a watertight expansion joint system, Contact WBA for recommendations.
- Periodically inspect the installed material and repair localized areas as needed. Inspect for loose components and/or hardware, repair as necessary. Consult a Watson Bowman Acme representative for additional information.
- Make certain the most current version of the product data sheet is being used. Please consult the website (www.wbacorp.com) or contact a customer service representative.
- Proper application is the responsibility of the user. Field visits by Watson Bowman Acme personnel are for the purpose of making technical recommendations only and not for supervising or providing quality control on the jobsite.

Related Documents:

- Material Safety Data Sheets
- Wabo®SeismicPan Specification
- Wabo®SeismicPan Sales Drawings
- Wabo®SeismicPan Installation Procedure

LIMITED WARRANTY:

Watson Bowman Acme Corp. warrants that this product conforms to its current applicable specifications. WATSON BOWMAN ACME CORP. MAKES NO OTHER WARRANTY, EXPRESS OR IMPLIED, INCLUDING ANY WARRANTY OF MERCHANTABILITY OR WARRANTY OF FITNESS FOR A PARTICULAR PURPOSE. The sole and exclusive remedy of Purchaser for any claim concerning this product, including, but not limited to, claims alleging breach of warranty, negligence, strict liability or otherwise, is the replacement of product or refund of the purchase price, at the sole option of Watson Bowman Acme Corp. Any claims concerning this product shall be submitted in writing within one year of the delivery date of this product to Purchaser and any claims not presented within that period are waived by Purchaser. IN NO EVENT SHALL WATSON BOWMAN ACME CORP. BE LIABLE FOR ANY SPECIAL, INCIDENTAL, CONSEQUENTIAL (INCLUDES LOSS OF PROFITS) OR PUNITIVE DAMAGES. Other warranties may be available when the product is installed by a factory trained installer. Contact your local Watson Bowman Acme representative for details. The data expressed herein is true and accurate to the best of our knowledge at the time published; it is, however, subject to change without notice.

Contact

Watson Bowman Acme Corp. 95 Pineview Drive, Amherst, NY 14228
phone: 716-691-7566 / fax: 716-691-9239 / web site: <http://www.wbacorp.com>

WaboSeismicPan_410