



Installation Procedure

Watson Bowman Acme Corp. 95 Pineview Drive Amherst, NY 14228

phone: (716) 691-7566 fax: (716) 691-9239

website: www.wbcorp.com

Information provided herein, including but not limited to, any drawing, design, photograph, graphic, or statement(s) ("Materials") are proprietary and the property of Watson Bowman Acme Corporation ("Company"). Reproduction, translation, or reduction to any electronic medium or machine readable form, in whole or part, is strictly prohibited, except for the express purpose for which it has been furnished, without prior written consent of Company. All Materials contained herein are provided by Company for information purposes only. Company reserves the right to amend or withdraw any information contained in the Materials without notice. All technical or other advice by Company, whether verbal or written, concerning products, or the use of products in specific situations ("Advice") is given by Company and is used at the Users own risk.

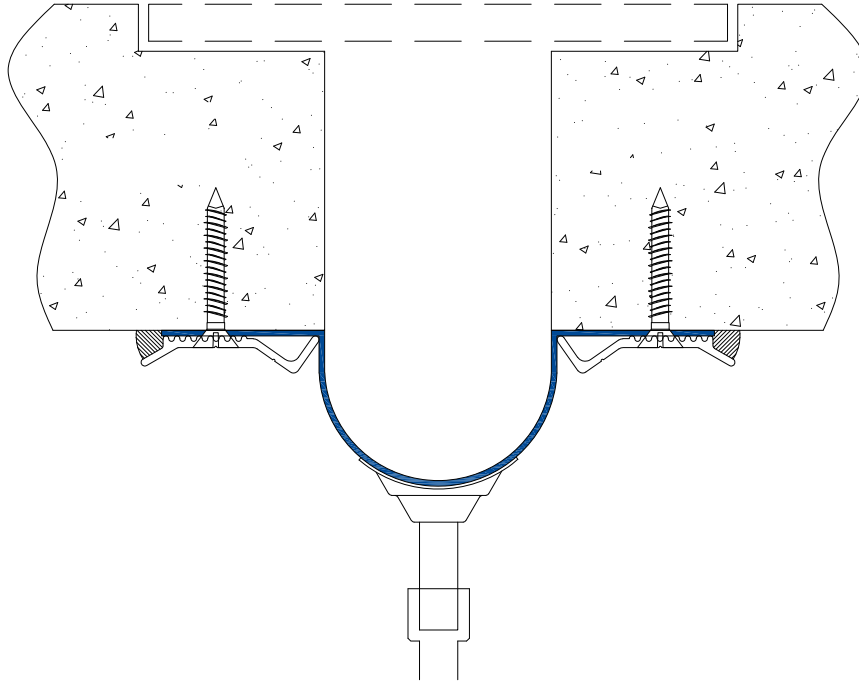

Wabo® GutterFlex Model(s) USG Moisture Barrier System

The following installation procedure is very important and must be fully understood prior to beginning any work. To ensure proper installation and performance of expansion joint system the following actions must be completed by the installing contractor. Failure to do so will affect product warranty.

- 1) Carefully read and understand installation procedure. Contact WBA's Technical Service Department at (800) 677-4922 for product assistance.
- 2) Inspect all shipments and materials for missing or damaged components and hardware. Contact Customer Service at (800) 677-4922 with WBA's order number and invoice for prompt assistance.
- 3) Inspect substrate or adjacent construction for acceptance before beginning work. Report unacceptable construction to the project manager for scheduled repair work.
- 4) Review WBA shop drawings for project specific detailed information if Engineering services were purchased at time of order.

Standard components

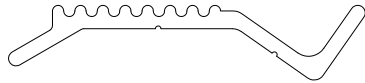

Extruded Aluminum Termination Bar (P/n: 3091)



1/4" x 1 3/4" Concrete Screw Anchor (P/n: 6517)

Components shown below vary in size depending on model of system

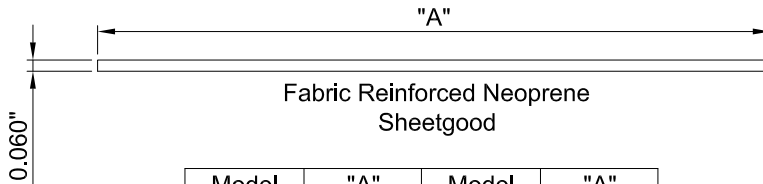

Model	"A"	Model	"A"
USG-12N	12"	USG-36N	36"
USG-18N	18"	USG-42N	42"
USG-24N	24"	USG-48N	48"
USG-30N	30"		

Optional Components

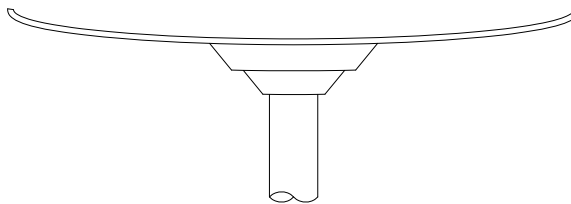

Factory Assembled Drain Tube
P/n: 3095

Splicing Components

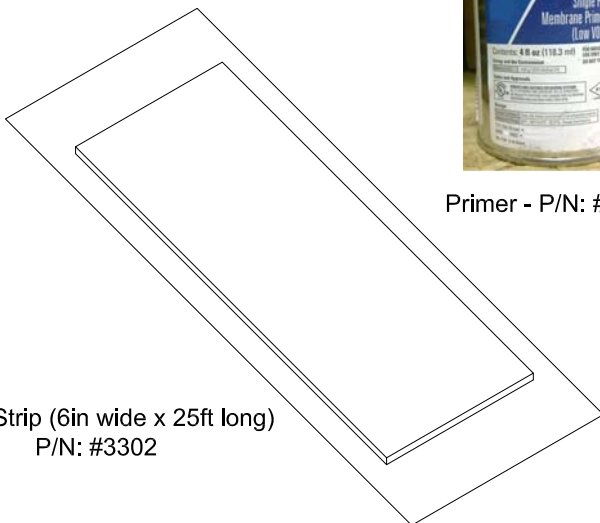

Splice Strip (6in wide x 25ft long)
P/N: #3302



Primer - P/N: #3303



Brush - P/N: #3304

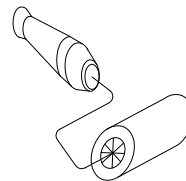

Seam Roller - P/N: #3097

Above components make up one GutterFlex Splice Kit (P/N: #3320)

Sheet
1
of 4

Watson Bowman Acme Corp.
95 Pineview Drive Amherst, NY 14228
phone: (716) 691-7566 fax: (716) 691-9239
website: www.wbacorp.com

Installation procedure: GutterFlex "USG" Sys.
Watson Bowman Acme Corp. reserves the right to amend or withdraw any information contained herein without notice and will not be responsible for any inaccuracy or ambiguity of any information contained herein.



Installation procedure: GutterFlex "USG" Sys.
Watson Bowman Acme Corp. reserves the right to amend or withdraw any information contained herein without notice and will not be responsible for any inaccuracy or ambiguity of any information contained herein.

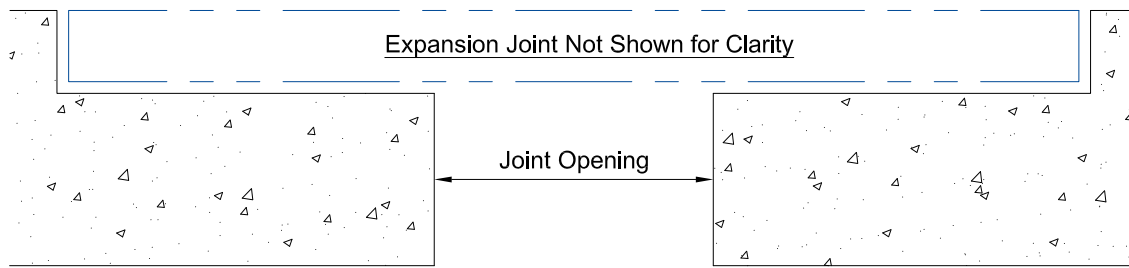

1 **Surface Preparation:** To properly achieve adhesion of sealants, all oils, grease, tars, coatings, asphalt and/or other contaminants must be removed. Sandblasting is the preferred method of cleaning the concrete. After cleaning, blow off all residue with compressed air.

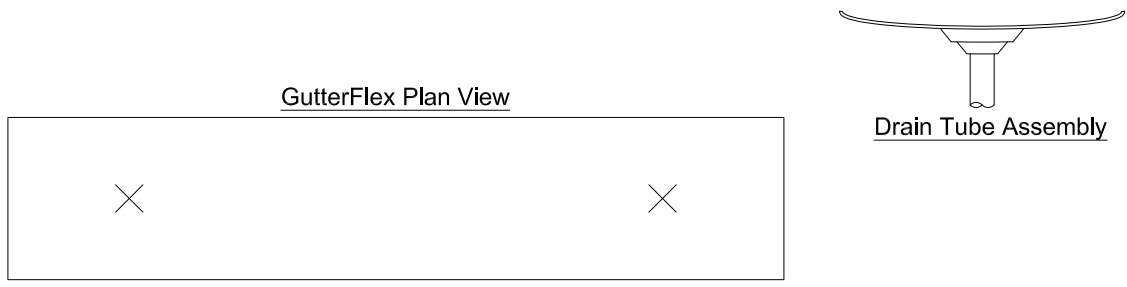

2 **Optional Drain Tube Assembly (If Required):** Layout fabric reinforced Moisture Barrier and mark drain locations with a "X"
Note: Drain tube locations are based on Job Specific Locations.

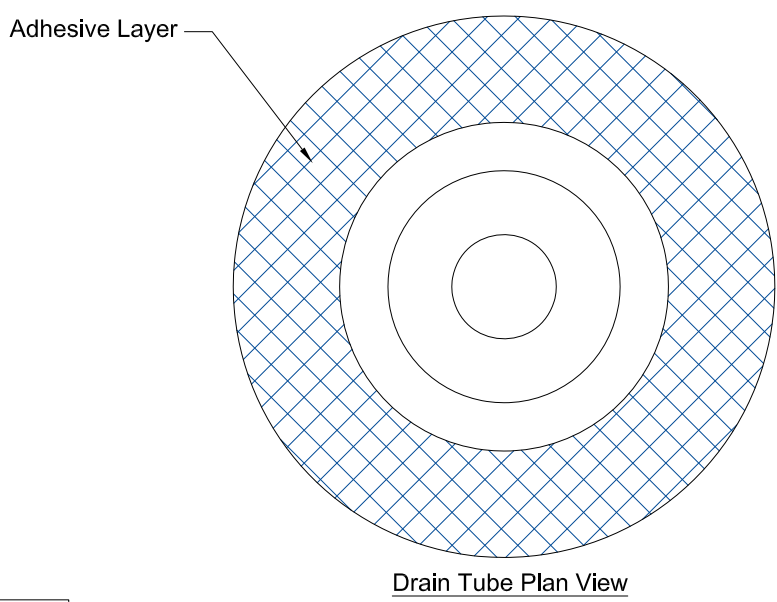

3 At Marked locations, cut holes in fabric reinforced moisture barrier slightly smaller than the inside circle layer with the peel away adhesive on the drain tube assembly.

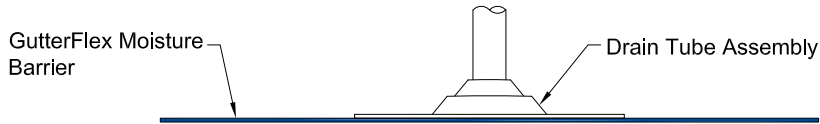

4

Clean area of Moisture barrier around the cut holes with Rubbing Alcohol. Peel paper off adhesive side of Drain Tube Assembly and adhere to Moisture Barrier, making sure that it is centered over the cut holes. Utilizing a seam roller, roll over the entire adhesive area to ensure a strong bond line between the two pieces.

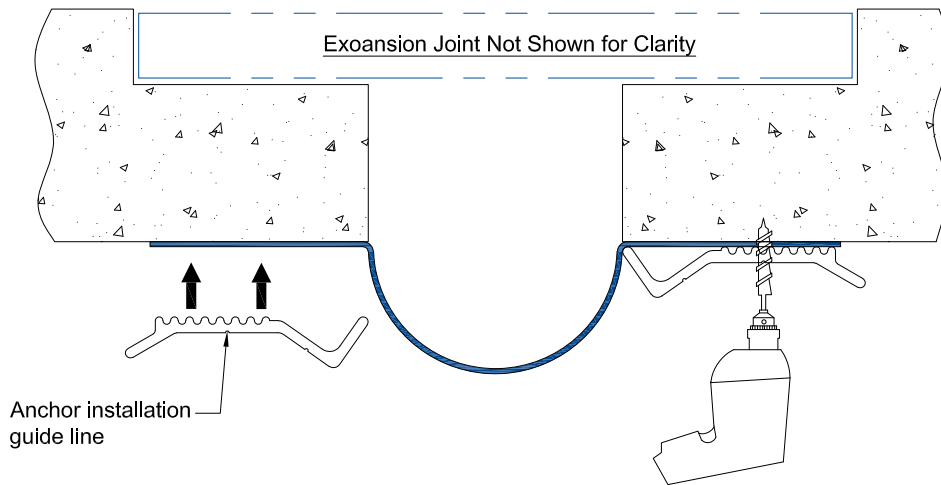

5

Mark and pre-drill anchor locations on the Aluminum Retainer spaced at 16" O.C starting 4" in from either end. Utilizing the pre-drilled Aluminum retainer, hold the Fabric reinforced Moisture Barrier and (Optional) Drain Tube Assembly under slab and press Aluminum Retainer against the concrete as shown. The Aluminum retainer will act as a template for locations where the contractor will need to drill for anchor installation.

Note: After anchor holes have been drilled, clean out holes of debris during the drilling process.

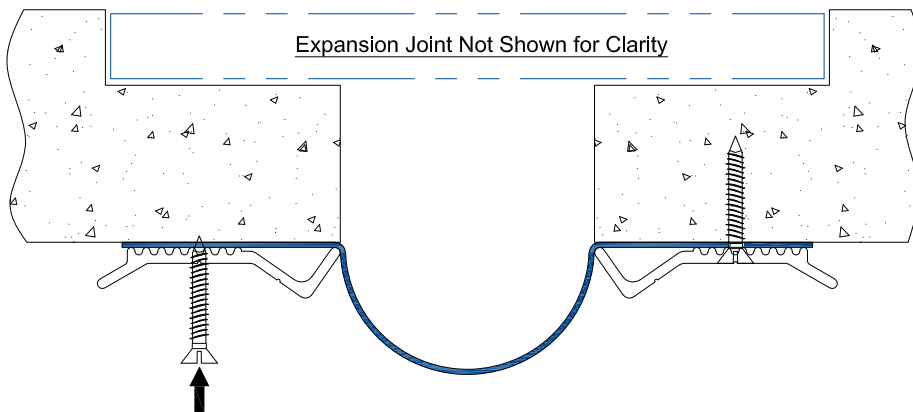

6

Contractor Note: Before installing the concrete screw anchors, apply a bead of sealant (By Others) on the underside of the concrete where the moisture barrier will be installed. This is to ensure that no water will propagate between the systems.

Utilizing the supplied concrete screw anchors, fasten the retainer and gutter system to the concrete slab. Fill void and the end of the retainer with sealant (By Others), as shown. Connect optional Drain Tube assembly to the projects drain system (By Others).

Installation procedure: GutterFlex "USG" Sys.
Watson Bowman Acme Corp. reserves the right to amend or withdraw any information contained herein without notice and will not be responsible for any inaccuracy or ambiguity of any information contained herein.

Splicing Instructions

Sheet
4
of 4

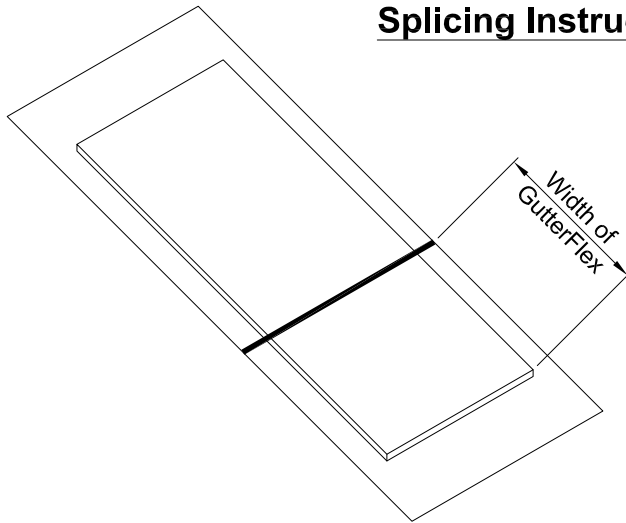

- 1 Cut splice strip to length that equals the width of the Fabric Reinforced GutterFlex.

- 2 Peel backing paper from Splice Strip

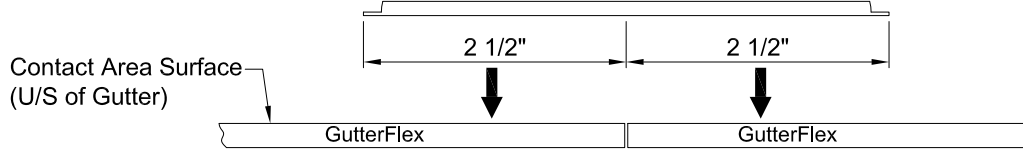

- 3 Clean contact area of GutterFlex to receive the Splice Strip with Mineral Spirits. Bring the two ends of the GutterFlex Moisture Barrier to within 1/64" of each other. Center splice strip over gap and apply to GutterFlex Moisture Barrier.

Note: After Splice strip has been applied, WBA Recommends using the Seam Roller to ensure that no air bubbles will be present and that the splice strip is well adhered to the GutterFlex. Pay special attention to all edges.

Watson Bowman Acme Corp.
95 Pineview Drive Amherst, NY 14228
phone: (716) 691-7566 fax: (716) 691-9239
website: www.wbacorp.com

Installation procedure: GutterFlex "USG" Sys.
Watson Bowman Acme Corp. reserves the right to amend or withdraw any information contained herein without notice and will not be responsible for any inaccuracy or ambiguity of any information contained herein.

**Watson
Bowman
Acme**



Installation Procedure

Watson Bowman Acme Corp. 95 Pineview Drive, Amherst, NY 14228

Phone: (716) 691-7566

fax: (716) 691-9239

Website: www.wbcorp.com

Information provided herein, including but not limited to, any drawing, design, photograph, graphic, or statement(s) ("Materials") are proprietary and the property of Watson Bowman Acme Corporation ("Company"). Reproduction, translation, or reduction to any electronic medium or machine readable form, in whole or part, is strictly prohibited, except for the express purpose for which it has been furnished, without prior written consent of Company. All Materials contained herein are provided by Company for information purposes only. Company reserves the right to amend or withdraw any information contained in the Materials without notice. All technical or other advice by Company, whether verbal or written, concerning products, or the use of products in specific situations ("Advice") is given by Company and is used at the Users own risk.



Wabo[®] GutterFlex Splice Detail & Drain Tube Assembly Installation Instructions

The following installation procedure is very important and must be fully understood prior to beginning any work. To ensure proper installation and performance of expansion joint system the following actions must be completed by the installing contractor. Failure to do so will affect product warranty.

1. Carefully read and understand installation procedure. Contact WBA's Technical Service Department at (800) 677-4922 for product assistance.
2. Inspect all shipments and materials for missing or damaged components and hardware. Contact Customer Service at (800) 677-4922 with WBA's order number and invoice for prompt assistance.
3. Inspect substrate or adjacent construction for acceptance before beginning work. Report unacceptable construction to the project manager for scheduled repair work.
4. Review WBA shop drawings for project specific detailed information if Engineering services were purchased at time of order.



Installation Procedure

Watson Bowman Acme Corp. 95 Pineview Drive, Amherst, NY 14228

Phone: (716) 691-7566

fax: (716) 691-9239

Website: www.wbacorp.com

Information provided herein, including but not limited to, any drawing, design, photograph, graphic, or statement(s) ("Materials") are proprietary and the property of Watson Bowman Acme Corporation ("Company"). Reproduction, translation, or reduction to any electronic medium or machine readable form, in whole or part, is strictly prohibited, except for the express purpose for which it has been furnished, without prior written consent of Company. All Materials contained herein are provided by Company for information purposes only. Company reserves the right to amend or withdraw any information contained in the Materials without notice. All technical or other advice by Company, whether verbal or written, concerning products, or the use of products in specific situations ("Advice") is given by Company and is used at the Users own risk.

1. Recommended Supplies & Storage

- Tape measure
- Sharp knife
- Wabo®GutterFlex Blockout System (see below)
- Wabo®GutterFlex Splice Tabs
- Wabo®GutterFlex Splice Primer (4oz can)
- Clean Cloth
- Plywood Sheet(s) - as working surface
- Wabo®GutterFlex Seam Rolling Tool (#3097)
- Wabo®GutterFlex Drain Tube (#3095)
- Bedding Tape (#2830)
- Heat Gun
- 2 Saw Horses
- Small disposable brush

⇒ Store material at minimum of 68°F (20°C) for a minimum of 24 hours prior to installation.

⇒ Store material in a dry enclosed area making sure materials are off the ground and out of direct sunlight. Shaded areas recommended. See sheet #3 for additional storage information.

2. Standard Components

Custom sizes / widths also available.

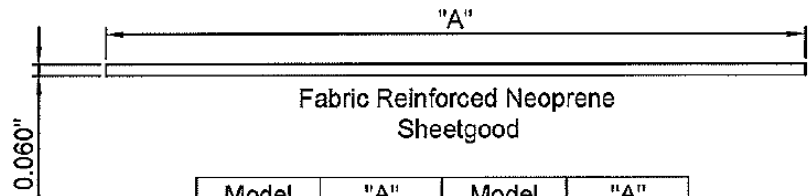

Model	"A"	Model	"A"
USG-12N	12"	USG-36N	36"
USG-18N	18"	USG-42N	42"
USG-24N	24"	USG-48N	48"
USG-30N	30"		

Components shown below vary in size depending on model or system

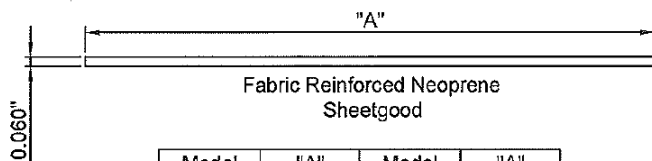

Model	"A"	Model	"A"
BOG-12N	12"	BOG-36N	36"
BOG-18N	18"	BOG-42N	42"
BOG-24N	24"	BOG-48N	48"
BOG-30N	30"		

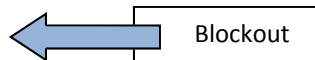
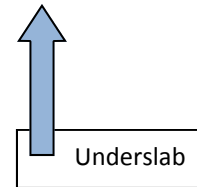



Installation Procedure

Watson Bowman Acme Corp. 95 Pineview Drive, Amherst, NY 14228

Phone: (716) 691-7566

fax: (716) 691-9239

Website: www.wbacorp.com

Information provided herein, including but not limited to, any drawing, design, photograph, graphic, or statement(s) ("Materials") are proprietary and the property of Watson Bowman Acme Corporation ("Company"). Reproduction, translation, or reduction to any electronic medium or machine readable form, in whole or part, is strictly prohibited, except for the express purpose for which it has been furnished, without prior written consent of Company. All Materials contained herein are provided by Company for information purposes only. Company reserves the right to amend or withdraw any information contained in the Materials without notice. All technical or other advice by Company, whether verbal or written, concerning products, or the use of products in specific situations ("Advice") is given by Company and is used at the Users own risk.

2. Standard Components (cont'd)



Seam Rolling Tool
WBA P/N #3097



Wabo®GutterFlex Drain Tube
WBA P/N #3095

3. Clean and Prepare Work Surface

Work Surface:

- Prior to beginning work, installer shall prepare a clean, sound work surface that will provide a stable, clean surface for the field assembly of the Wabo®GutterFlex Splice.
- Confirm joint substrate is dry, clean and ready for the Wabo®GutterFlex.
- Best practice would be a clean, dry sheet of plywood resting safely on two saw horses.





Installation Procedure

Watson Bowman Acme Corp. 95 Pineview Drive, Amherst, NY 14228

Phone: (716) 691-7566

fax: (716) 691-9239

Website: www.wbcorp.com

Information provided herein, including but not limited to, any drawing, design, photograph, graphic, or statement(s) ("Materials") are proprietary and the property of Watson Bowman Acme Corporation ("Company"). Reproduction, translation, or reduction to any electronic medium or machine readable form, in whole or part, is strictly prohibited, except for the express purpose for which it has been furnished, without prior written consent of Company. All Materials contained herein are provided by Company for information purposes only. Company reserves the right to amend or withdraw any information contained in the Materials without notice. All technical or other advice by Company, whether verbal or written, concerning products, or the use of products in specific situations ("Advice") is given by Company and is used at the Users own risk.

4. Splice Procedure

1. Place equal size pieces of Wabo®GutterFlex end-to-end on your clean, dry work surface so that a straight, even butt splice is formed.
2. Use the provided Wabo®GutterFlex Splice Primer and prep at least 3.0" of material on each side of the butt splice (see below). Fully coat (etch) the 3.0" area on each side with Primer, then allow 2-3 minutes for it to 'flash off'. Care should be used to ensure that this area remains clean.
3. Gently press the Wabo®GutterFlex Splice Tab onto the primed / etched area. Use the roller to roll out all air pockets for stronger bond between Splice Tab and Wabo®GutterFlex. Start at one side and work your way across the entire Splice Tab.
4. For best splice performance, apply light heat to splice tab during rolling operation (see Image #1 next page). Allow to cool before flipping Wabo®GutterFlex to opposite side.
5. Gently flip the Wabo®GutterFlex System over and repeat Steps #1 to #4 on the underside to ensure both side of the butt splice are covered with a Wabo®GutterFlex Splice Tab.

INSTALLATION TIP: In cold temperatures, store material in a heated area 24hrs prior to installation. In hot temperatures, store material out of direct sunlight and not in an enclosed storage container where temperatures may exceed 100°F (38°C).

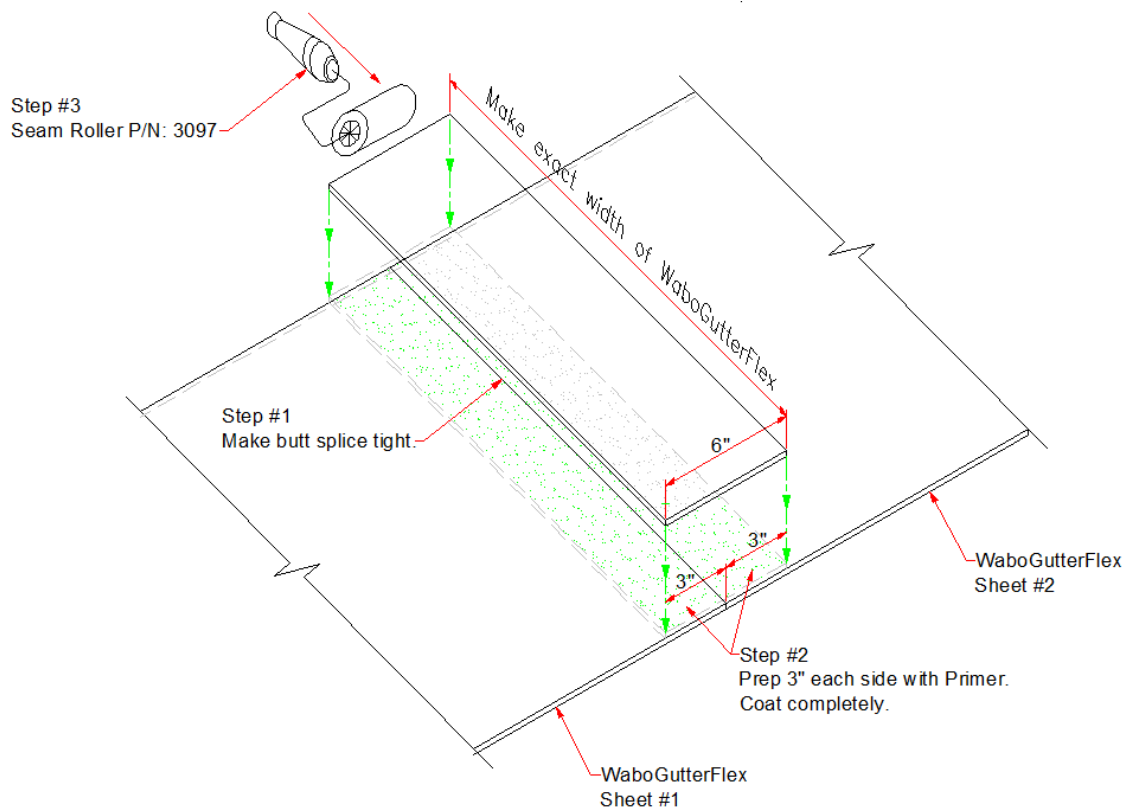



Installation Procedure

Watson Bowman Acme Corp. 95 Pineview Drive, Amherst, NY 14228

Phone: (716) 691-7566

fax: (716) 691-9239

Website: www.wbacorp.com

Information provided herein, including but not limited to, any drawing, design, photograph, graphic, or statement(s) ("Materials") are proprietary and the property of Watson Bowman Acme Corporation ("Company"). Reproduction, translation, or reduction to any electronic medium or machine readable form, in whole or part, is strictly prohibited, except for the express purpose for which it has been furnished, without prior written consent of Company. All Materials contained herein are provided by Company for information purposes only. Company reserves the right to amend or withdraw any information contained in the Materials without notice. All technical or other advice by Company, whether verbal or written, concerning products, or the use of products in specific situations ("Advice") is given by Company and is used at the Users own risk.

5. Apply Heat for 2-3 minutes to cure adhesion.

Caution: Do not use excessive heat. That could damage the material.



6. Side #1 - Completed.

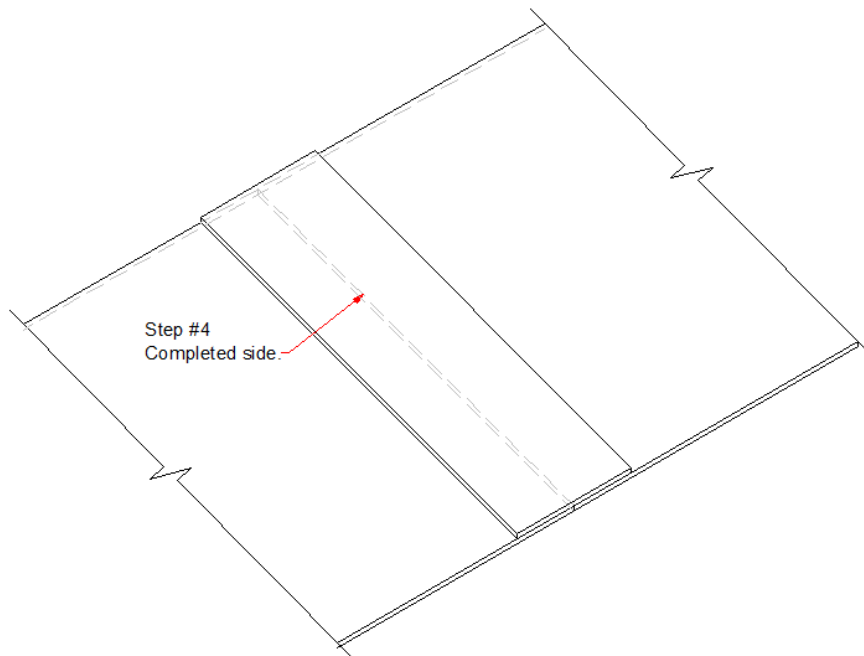



Installation Procedure

Watson Bowman Acme Corp. 95 Pineview Drive, Amherst, NY 14228

Phone: (716) 691-7566

fax: (716) 691-9239

Website: www.wbcorp.com

Information provided herein, including but not limited to, any drawing, design, photograph, graphic, or statement(s) ("Materials") are proprietary and the property of Watson Bowman Acme Corporation ("Company"). Reproduction, translation, or reduction to any electronic medium or machine readable form, in whole or part, is strictly prohibited, except for the express purpose for which it has been furnished, without prior written consent of Company. All Materials contained herein are provided by Company for information purposes only. Company reserves the right to amend or withdraw any information contained in the Materials without notice. All technical or other advice by Company, whether verbal or written, concerning products, or the use of products in specific situations ("Advice") is given by Company and is used at the Users own risk.

6. Both Sides—Completed.

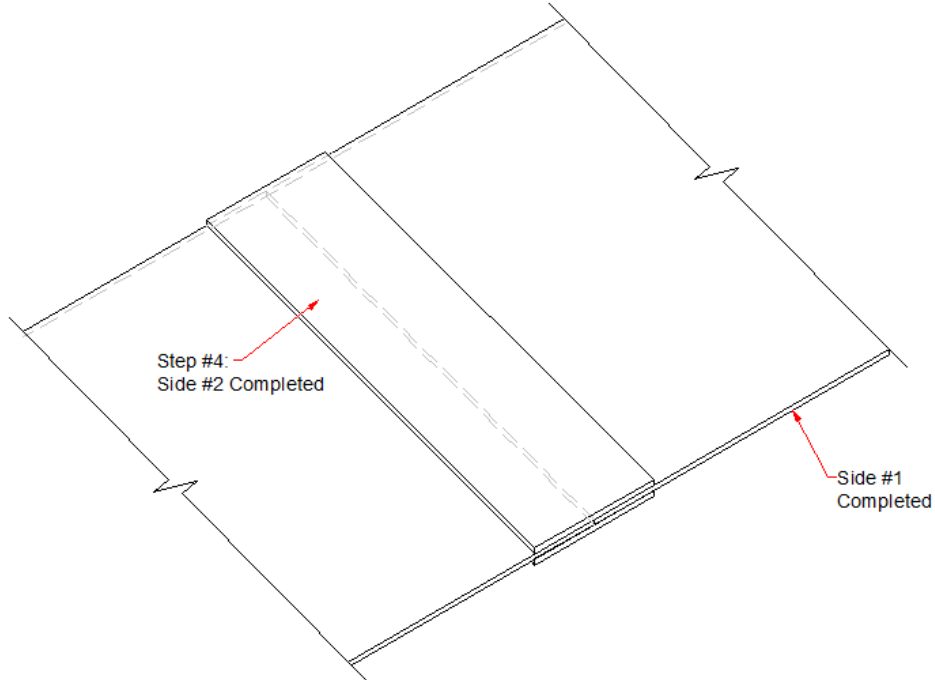



Installation Procedure

Watson Bowman Acme Corp. 95 Pineview Drive, Amherst, NY 14228

Phone: (716) 691-7566

fax: (716) 691-9239

Website: www.wbcorp.com

Information provided herein, including but not limited to, any drawing, design, photograph, graphic, or statement(s) ("Materials") are proprietary and the property of Watson Bowman Acme Corporation ("Company"). Reproduction, translation, or reduction to any electronic medium or machine readable form, in whole or part, is strictly prohibited, except for the express purpose for which it has been furnished, without prior written consent of Company. All Materials contained herein are provided by Company for information purposes only. Company reserves the right to amend or withdraw any information contained in the Materials without notice. All technical or other advice by Company, whether verbal or written, concerning products, or the use of products in specific situations ("Advice") is given by Company and is used at the Users own risk.

This page intentionally left blank.



Installation Procedure

Watson Bowman Acme Corp. 95 Pineview Drive, Amherst, NY 14228

Phone: (716) 691-7566

fax: (716) 691-9239

Website: www.wbcorp.com

Information provided herein, including but not limited to, any drawing, design, photograph, graphic, or statement(s) ("Materials") are proprietary and the property of Watson Bowman Acme Corporation ("Company"). Reproduction, translation, or reduction to any electronic medium or machine readable form, in whole or part, is strictly prohibited, except for the express purpose for which it has been furnished, without prior written consent of Company. All Materials contained herein are provided by Company for information purposes only. Company reserves the right to amend or withdraw any information contained in the Materials without notice. All technical or other advice by Company, whether verbal or written, concerning products, or the use of products in specific situations ("Advice") is given by Company and is used at the Users own risk.

1. Drain Tube Assembly (optional)

1. For proper construction of your Drain Tube Assembly we recommend using the same plywood / sawhorse work bench used for the Splice; however it is now recommended to drill a hole in the center of the plywood (minimum diameter = 3.5") to allow the Drain Tube to hang freely through the opening.



Drill hole in center of plywood per instructions above.

2. Wabo®GutterFlex Sheet Good prep...

1. Rollout Wabo®GutterFlex sheetgood on top of plywood worksurface.
2. Invert Drain Tube Assembly, place on top of Wabo®GutterFlex and trace outside diameter as shown below.

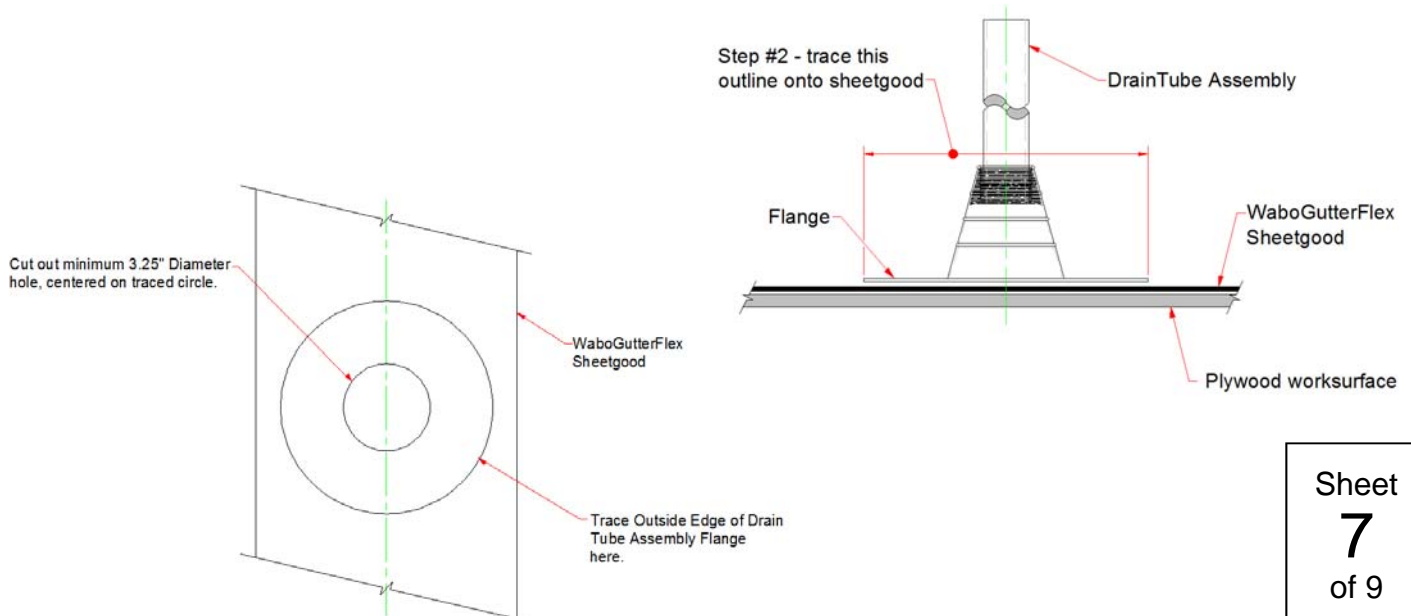



Installation Procedure

Watson Bowman Acme Corp. 95 Pineview Drive, Amherst, NY 14228

Phone: (716) 691-7566

fax: (716) 691-9239

Website: www.wbcorp.com

Information provided herein, including but not limited to, any drawing, design, photograph, graphic, or statement(s) ("Materials") are proprietary and the property of Watson Bowman Acme Corporation ("Company"). Reproduction, translation, or reduction to any electronic medium or machine readable form, in whole or part, is strictly prohibited, except for the express purpose for which it has been furnished, without prior written consent of Company. All Materials contained herein are provided by Company for information purposes only. Company reserves the right to amend or withdraw any information contained in the Materials without notice. All technical or other advice by Company, whether verbal or written, concerning products, or the use of products in specific situations ("Advice") is given by Company and is used at the Users own risk.

8. Drain Tube Assembly prep...

1. Fully coat (etch) the area shown below on the Wabo®GutterFlex sheetgood using the Primer provided.
2. Fully coat (etch) the area shown below on the Drain Tube Assembly Flange using the Primer provided.
3. Allow 2-3 minutes for it to 'flash-off' properly.

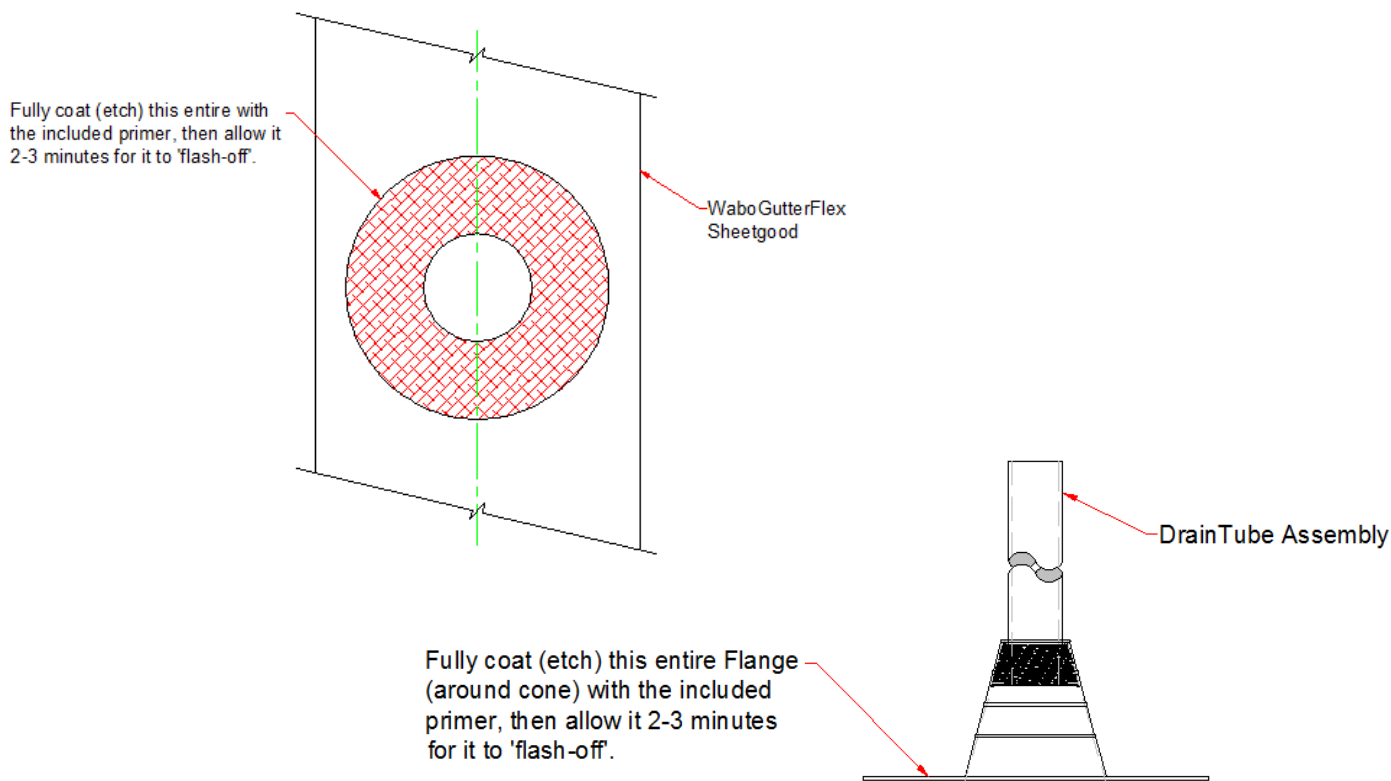

9. Apply bedding tape to Wabo®GutterFlex...

Ensure Flange edges are bonded to sheet good around its entire circumference.

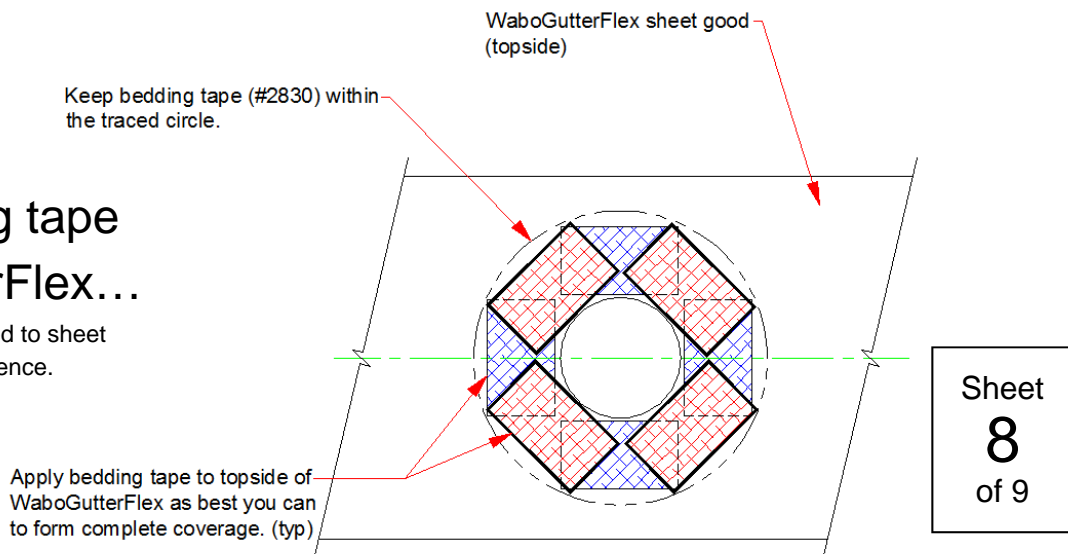

Information provided herein, including but not limited to, any drawing, design, photograph, graphic, or statement(s) ("Materials") are proprietary and the property of Watson Bowman Acme Corporation ("Company"). Reproduction, translation, or reduction to any electronic medium or machine readable form, in whole or part, is strictly prohibited, except for the express purpose for which it has been furnished, without prior written consent of Company. All Materials contained herein are provided by Company for information purposes only. Company reserves the right to amend or withdraw any information contained in the Materials without notice. All technical or other advice by Company, whether verbal or written, concerning products, or the use of products in specific situations ("Advice") is given by Company and is used at the Users own risk.

10. Drain Tube Assembly Assembly...

1. Apply Drain Tube Assembly to WaboGutterFlex sheet good by allowing drain tube to hang through the hole in the WaboGutterFlex and the plywood worksurface.
2. Gently press the 2 items together (shown below).
3. Use roller across entire surface to press any trapped air out. (Required for proper watertight seal).

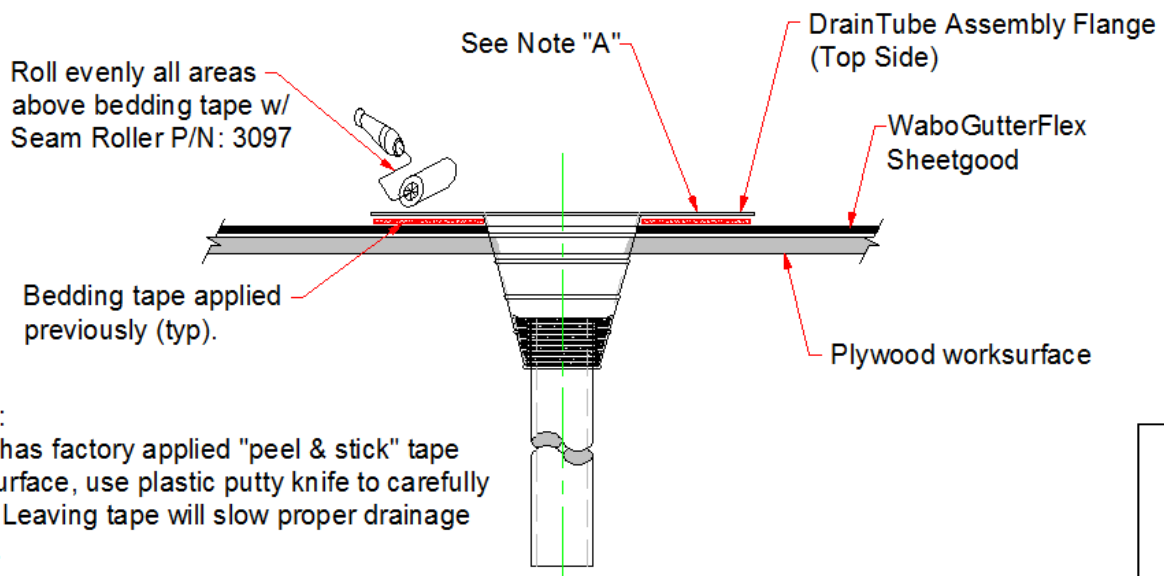
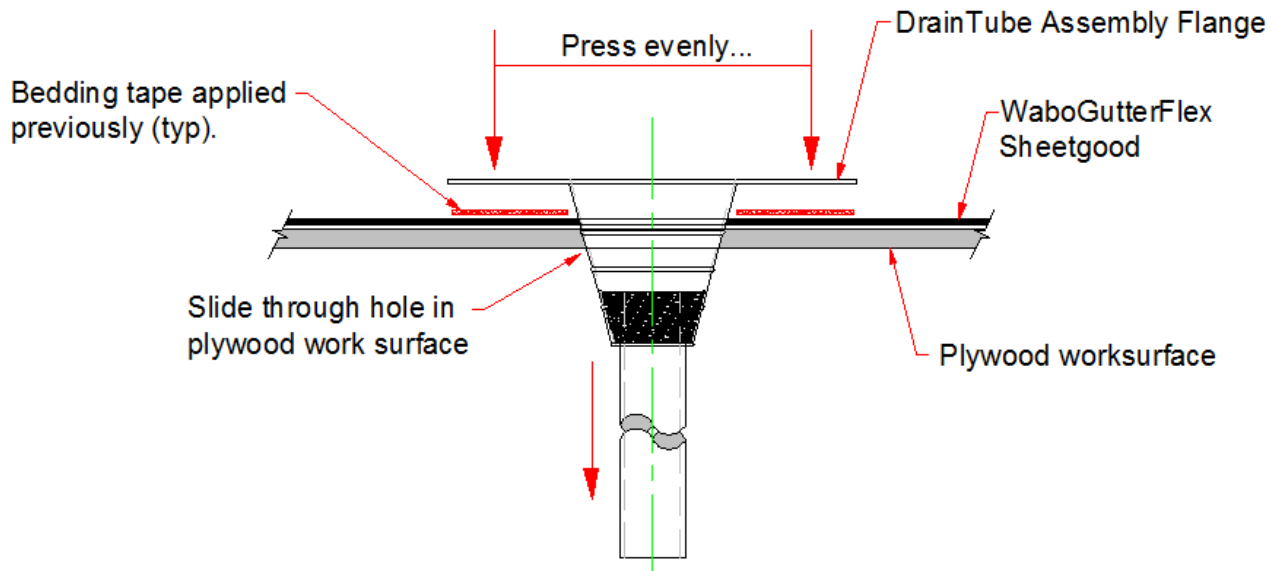

Note "A":
If flange has factory applied "peel & stick" tape on top surface, use plastic putty knife to carefully remove. Leaving tape will slow proper drainage of water.